

Ra	0.2	1.6	6.3	25
JIS	▽▽▽	▽▽	▽	▽
GENERAL TOLERANCE	±0.1 0.5~5	±0.2 6~30	±0.3 31~120	±0.5 121~320
	±0.8 321~1000			

HAITIMA CORPORATION  
 P.O.BOX 34-36 TAIPEI  
 Tel:+886-2-26585800  
 E-mail:haitima@seed.net.tw  
 www.haitima.com.tw  
 TAIWAN R.O.C.  
 Fax:+886-2-26582266

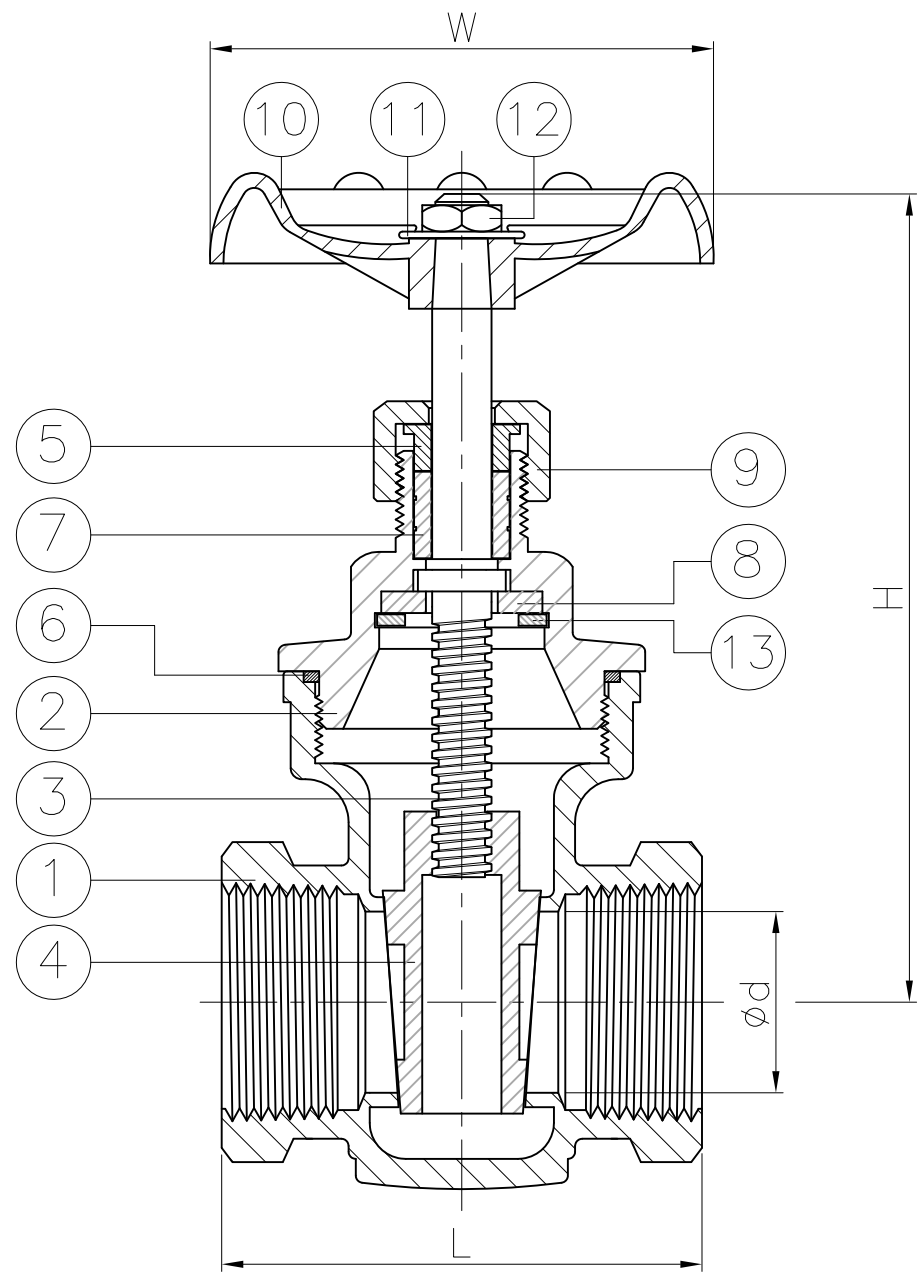

DN	d	L	H	W	Weight(kg)
15	16.1	57	101	62	0.5
20	20.3	60.5	108	62	0.6
25	25	67	118	73	0.8
32	31.8	76	129	73	1.2
40	37.5	87	173	95	2
50	48.3	94	186	100	2.8
65	65	114	210	110	4.6
80	80	131	230	110	6.7

unit:mm

NPS	d	L	H	W	Weight(lb)
1/2"	0.63	2.24	3.98	2.44	1.1
3/4"	0.8	2.38	4.25	2.44	1.4
1"	0.98	2.64	4.65	2.87	1.8
1-1/4"	1.25	2.99	5.08	2.87	2.6
1-1/2"	1.48	3.43	6.81	3.74	4.4
2"	1.9	3.7	7.32	3.94	6.2
2-1/2"	2.56	4.49	8.27	4.33	10.1
3"	3.15	5.16	9.06	4.33	14.8

unit:in

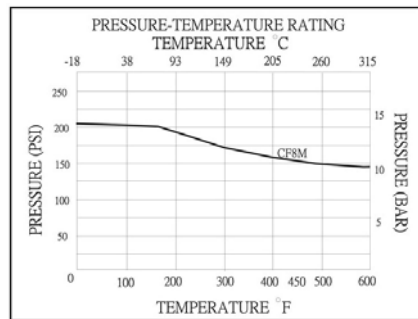

\*Non-rising stem

ITEM	PARTS	MATERIAL
1	BODY	ASTM A351-CF8M
2	BONNET	
3	STEM	SS 316
4	DISC	
5	GLAND	ASTM A351-CF8M
6	GASKET	PTFE
7	PACKING	
8	WASHER	SS 304
9	GLAND NUT	ASTM A351-CF8M
10	HANDWHEEL	FC-150
11	WASHER	SS 304
12	NUT	
13	C-SNAP RING	SS 301

△			
△			
△			
Revise	Description	Date	Approve
DRAWING NO.		2029001XY -13	

**HAITIMA CORPORATION**  
Ball Valves

CHECK BY	DRAWING BY	DATE	SPECIFICATION	Screwed End Gate Valve 200WOG
	Ray	Jan.24.2013	MATERIAL	CF8M
			PROCESS/Nr.	
			UNIT / SCALE	mm